

# Conveyor T3



## Standard features:

- Buffering conveyor sections
- Stable and rigid construction
- Board thickness down to 0.4mm
- PLC controlled
- Motorized width adjustment
- SMEMA interface

The T3 conveyor is a sectioned conveyor with a rigid framework. Each side and section of the conveyor has its own motor, belt and board-present sensor, enabling a board to be buffered on each section and provide smooth, reliable transportation of PCBs.

Communication with preceding and following units is done via the standard SMEMA interface, which makes the conveyor easy to install in an electronics assembly line. The board train function with controlled high speed transportation and automatic width adjustment are two optional features that increase throughput and reduce the need for manual interventions, i.e. features that are eligible especially in high-mix / high-volume production.

Conveyor width adjustment is motorized as standard. Motors and cables are housed in the conveyor profile, giving a clean outlook to the unit. The conveyor or frame is used for housing connectors, PLC and associated control electronics.

## Technical information:

- Board transport level: 940 ± 30 mm (37 ± 1.2")
- Buffering zone length: 500 mm (19.7")
- Board length: 70 - 470 mm (2.8 - 18.5")
- Board width: 50 - 508 mm (2 - 20")
- Board thickness: 0.4 - 6 mm (0.016 - 0.24")
- Max. board weight: 5 kg (11 lbs)
- Board edge clearance: 3 mm (0.12")
- Max. board warpage width: 0.5%
- Voltage: 100 - 240 VAC, 50/60 Hz
- SMEMA Interface

## Options:

- Safety covers ESD, Safety covers ESD + safety loop
- Adjustable transport speed for interfacing reflow ovens
- Automatic width adjustment
- External barcode reader for serial start on MYDATA machines
- Board train function
- Start of line/End of line function
- Board stop for inspection

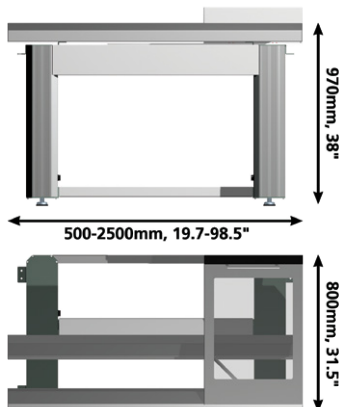

- Order codes:
- |                                   |                                   |
|-----------------------------------|-----------------------------------|
| Conveyor T3 500mm, K-017-0516     | Conveyor T3 1700mm, K-017-0755    |
| Conveyor T3/T4 700mm, K-017-0517  | Conveyor T3 2000mm, K-017-0520    |
| Conveyor T3 1000mm, K-017-0518    | Conveyor T3/T4 2250mm, K-017-0752 |
| Conveyor T3/T4 1200mm, K-017-0626 | Conveyor T3 2500mm, K-017-0521    |
| Conveyor T3 1500mm, K-017-0519    |                                   |