

Workstation T3

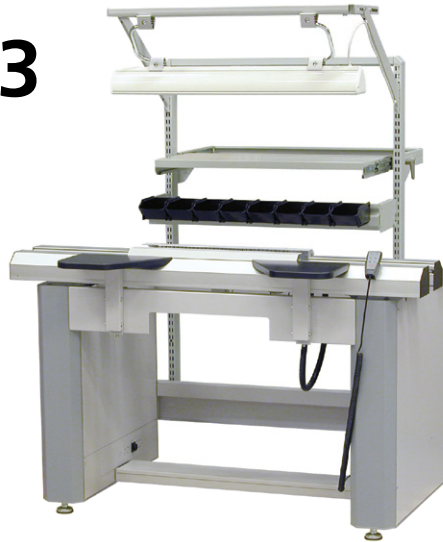

Standard features:

- Board stop function, board release, arm rests
- Stable and rigid construction
- Board thickness down to 0.4mm
- PLC controlled
- Motorized width adjustment
- SMEMA interface

The T3 workstation is built around the standard T3 conveyor and enables manual assembly work and inspections to be carried out on PCBs in-line. Each side and section of the conveyor has its own motor and belt, providing smooth and reliable transportation of PCBs.

Communication with preceding and following units is done via the standard SMEMA interface, which makes the conveyor easy to install in an electronics assembly line.

Width adjustment is motorized as standard. Motors and cables are housed in the conveyor profile, giving a clean outlook to the unit. The conveyor frame is used for housing connectors, PLC and associated control electronics.

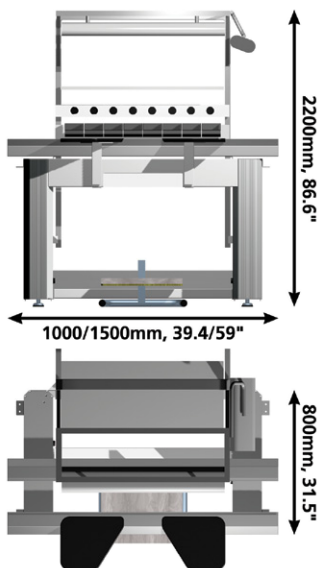

Technical information:

- Board transport level: 940 ± 30 mm (37 ± 1.2")
- Buffering zones: 1000mm = 2, 1500mm = 3
- Board length: 70 - 470 mm (2.8 - 18.5")
- Board width: 50 - 508 mm (2 - 20")
- Board thickness: 0.4 - 6 mm (0.016 - 0.24")
- Max. board weight: 5 kg (11 lbs)
- Board edge clearance: 3 mm (0.12")
- Max. board warpage width: 0.5%
- Voltage: 100 - 240 VAC, 50/60 Hz
- SMEMA Interface

Options:

- Safety covers ESD
- Adjustable transport speed
- Automatic width adjustment
- PCB reject & inspection lift
- Framework with lighting, boxes, shelves
- Foot rest, board release foot pedal

Order codes: Workstation T3 1000mm, K-017-0533
Workstation T3 1500mm, K-017-0535